

## DISCUS – All officials must sign the attached “Officials sign-in sheet”

Results must be sent to the computer room following the completion of each age group’s event

### NEW CENTRE RECORDS

- Key Officials must note the record of the event they are conducting. For a record to be recognized, the key Official must seek verification by a Committee Member immediately. All marks must be left unaltered until the record has been validated.

### EQUIPMENT

- 2 x Sector and Circle: Clearly marked (as below)
- 2 x Measuring Tapes
- Discus (SEE BELOW)
- 2 x Spikes: To hold zero end of tape at the nearest edge of the mark made by the discus on landing
- Place Tickets: To record performance for each child
- Recording Sheet: For recording all performances at venue
- Cloths: To wipe and clean discus
- Broom: To sweep Inside surface of discus circle
- 2 x Recorder’s table and chair

### IMPLEMENT WEIGHTS

- U6 - 8: 350 gm
- U9 - 10: 500 gm
- U11 - 13G & U11 -12B: 750 gm
- U14 - 15G & U13 - 15B: 1 kg

### OFFICIALS REQUIRED

#### (3 + Age Manager at each location)

- One official at throwing circle. Tasks: watching for foul throws, pulling the end of the tape back through the centre of the circle.
- One official at side of Sector. Tasks include locating and marking the impact point of the discus and returning discus to the circle
- One official for recording.
- Age Manager to assist with the order of competitors

### EVENT SAFETY

- Discus circles should be enclosed with a cage, and an extending fence to protect other areas on which events may be conducted should also be considered.
- The Chief Official should stand alongside the ring in a safe position on the right hand side of a right handed thrower and vice-versa.
- Apart from the Chief Official and the Official on the Sector line and/or spiking, everyone should stand behind the athlete, outside and at least 1m away from the safety cage and the landing sector should be clear.
- The discus should be **CARRIED** back to the circle - never thrown.
- Equipment **MUST NOT** be used without adequate supervision

### VENUE DIMENSIONS

- The discus is thrown from a circle into a sector of 40°. The Inside diameter of the circle is 2.50m. All lines used to mark the circle and sector, are 50mm wide. The Circle is divided into halves as shown

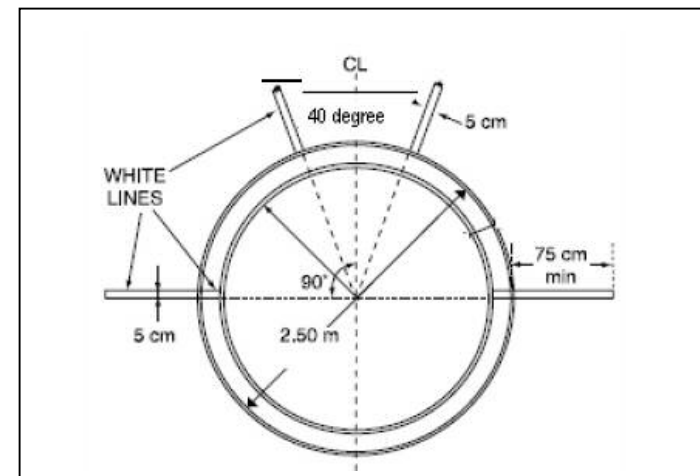

## ORDER OF EVENTS

- Events should be conducted in the order in which they appear on the daily running sheet. If appropriate, this order **may** be changed but **only** with the prior approval of the Arena Manager.

## PACK UP

- All equipment must be checked, cleaned and returned to the shed at the conclusion of the day's competition

## NUMBER OF TRIALS

- Each athlete is entitled to 3 trials **unless advised otherwise by the Arena Manager**
- All athletes in an age group **must** have the same number of trials
- All athletes complete their 3 trials **before** the next athletes' turn.

## VALID TRIAL

- The trial must be commenced from a stationary position.
- The athlete must not leave the circle until the discus has landed.
- The athlete must not touch the top of the circle or the ground outside the circle during the trial with any part of their body. They are allowed to touch the inside of the circle.
- The discus must land in a manner whereby the mark is within the inner edges of the lines marking the sector.
- The athlete may enter the circle from any direction (preferably from the rear half of the circle) but must exit from the rear half of the circle.
- The athlete may, during the course of each trial, stop and place the discus down in the circle and then recommence the trial again, providing that this occurs only once in any one trial, and that no other infringement has occurred.
- If the athlete drops the discus it may not be picked up and shall be recorded as a "No Throw (NT)".

## METHOD OF MEASUREMENT

- Officials select the imprint mark made by the discus on landing closest to the circle. The selected point is marked by the spike and the zero end of the tape is held at the spike.
- The tape is straightened (untwisted) and drawn tight through the centre of the circle.
- The distance is measured at the point where the tape crosses the inner edge of the circle.
- Each measurement is to the nearest cm **below** the distance thrown unless the reading is a whole centimetre.
- If the discus hits the cage and deflects back into the sector it shall be a valid trial and measured providing no other infringement occurs.

## RECORDING

- Best performances should be circled
- Ties are broken by referring to the next best throw.

| Athlete: | 1st trial, | 2nd trial, | 3rd trial, | Best, | Place              |
|----------|------------|------------|------------|-------|--------------------|
| A:       | 14.75,     | NT,        | 14.62,     | 14.75 | (4 <sup>th</sup> ) |
| B:       | 15.35,     | 14.92,     | 15.87,     | 15.87 | (2 <sup>nd</sup> ) |
| C:       | 14.65,     | 14.35,     | 14.75,     | 14.75 | (3 <sup>rd</sup> ) |
| D:       | 15.87,     | 15.35,     | 15.03,     | 15.87 | (1 <sup>st</sup> ) |

- D beats B by counting back to each athletes 3rd best trial (D - 15.03; B - 14.92).
- C beats A by counting back to each athletes 2nd best trial (C - 14.65; A - 14.62).
- NT should be used to indicate an invalid throw

### NOTE:

1. On the schematic of the throwing circle the angle should read 34.92 degrees not 40 degrees (changed at 2007 State Conference).
2. The landing sector lines 20 metres out from the centre of the throwing circle should be 12 metres apart.